

Dehumidifer

Performance Curve Chart

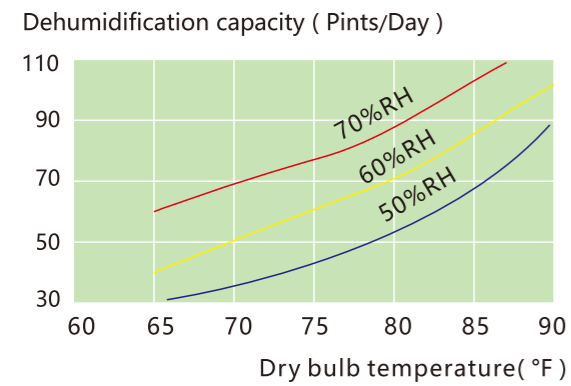

LG 70 Exterior Dimensions

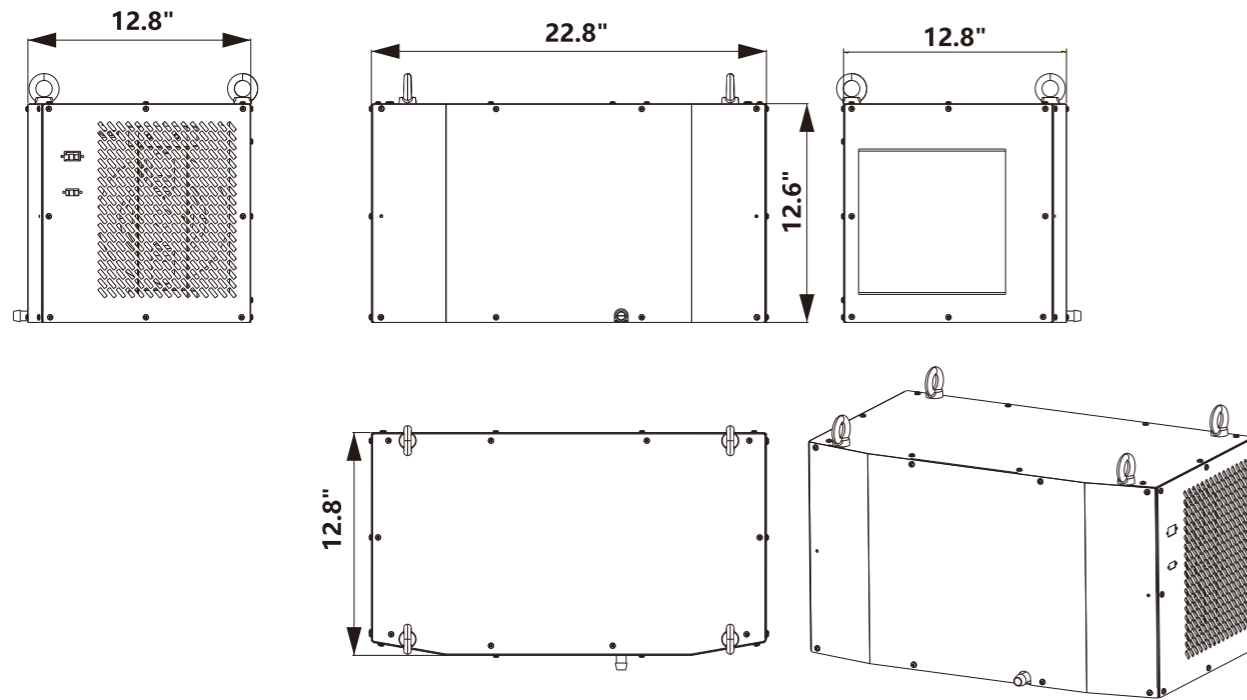

Schematic Diagram of the Structure



FEATURES:

Compact yet powerful, the LEIZIG dehumidifier offers a versatile dehumidification range from 70-880pints/day.

Boasting a high-efficiency filtration system, it ensures your plants are safeguarded from detrimental microbes.

Experience industry-leading minimal noise operation.

When paired with AHU, it excels in managing humidity in environments with low temperatures and elevated humidity levels.

Choose from a variety of installation options including hoisting, ceiling, wall, and floor cabinets – there's a fit for every preference.

Model No.	LG 70
Factory ID No.	31000010
Dimension (W×H×D)	22.8"*12.8"*12.8"

Technical parameter	LG 70
Capacity(Pints/Day)	70 Pints/Day
Efficiency	4.4 Pints/kWh
Refrigerant Type	R410A/11b
Refrigerant Amount	1lb.0oz
Operating Temp(°F)	56-95
Drain Connection	1/2"Theraded NPT
Air Filter	MERV-11/11"*8.6"*1"
Blower (Tested with duct collars on)	150CFM @ 0.0"WG
BTU/H	6700
Energy Factor	2.1 L/kWh

Electrical parameters	LG 70
Supply Voltage(V)	110~120VAC/1Ph/60Hz
Power(W)	645 W
Current Draw	5.8 A
Power Cord	Cord not provided-Direct wired only
Display mode	Plug-in connector

Attachment parameters	LG 70
Weight(lb)	56
Installation method	Ceiling-suspended
Component Material	Galvanized steel/powder electroplated paint (stainless steel housing optional)
Safety parameters	In accordance with DIN 31001
Environmental parameters	Max. ambient temperature 131 °F, max RH 80%, L35/L35(EN814)
Protection level	IP23
Standard of delivery	Dehumidifier actual machine, installation instructions, installation spare parts, quick plug (optional controller, import flange, export flange)
Surface color	RAL7035 (light grey) +RAL1033 (Orange), other colors on request
Certification	CE/UL

Dehumidification Series

Dehumidification Series